

# HeatStation™

CONDENSING HYDRONIC HEAT ENGINE

Model: **HS 1500**

Input Btu/h Maximum	1,500,000
Output Btu/h Maximum	1,437,000
Minimum Firing Rate Btu/h	300,000
* Thermal efficiency at full firing rate	95.8%
Flow rates maximum/minimum (gpm)	250 / 30
Pressure drop at 40°F ΔT (72 gpm)	5 Ft. Hd.
Pressure drop at 30°F ΔT (108 gpm)	9 Ft. Hd.
Pressure drop at 20°F ΔT (143 gpm)	15 Ft. Hd.

Gas Connection (refer to manual for sizing)	1-1/2"
**Minimum Inlet Flow Gas Pressure	3.5" W.C.
**Maximum Static Gas Pressure	14" W.C.
Electrical amps at 120V, 60 Hz	8
Empty Wt - Lbs	1260
Shipping Wt - Lbs	1490
Operating Wt - Lbs	1490

\* Efficiency certified by testing per 10 CFR 431 (80°F to 180°F). Consult installation manual for glycol loops. Dimensions are in inches unless otherwise specified. For standard and optional equipment, see form 34-1150. \*\*Figures are for natural gas (S.G. 0.6). Consult factory for propane.

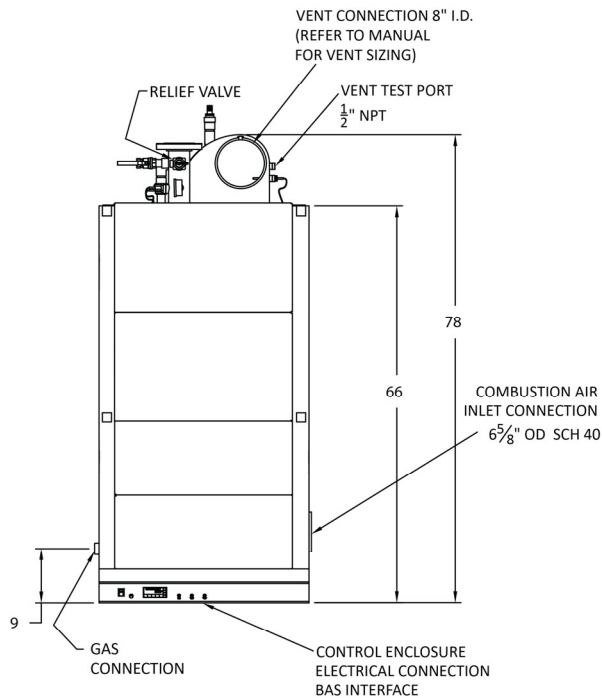

### Venting

230 eq. ft. using 6" diameter vent. Consult manual for longer vents. Use PVC, CPVC, Polypropylene or listed stainless steel vent. Consult manual for appropriate vent material at different boiler loop temperatures. Minimum vent length is 5 eq. feet.

### Inlet Combustion Air Duct

230 eq. ft. using 6" dia. PVC or galvanized vent pipe. Consult manual for longer vents.

### Minimum Service Clearances

18" from sides, 24" from front and top

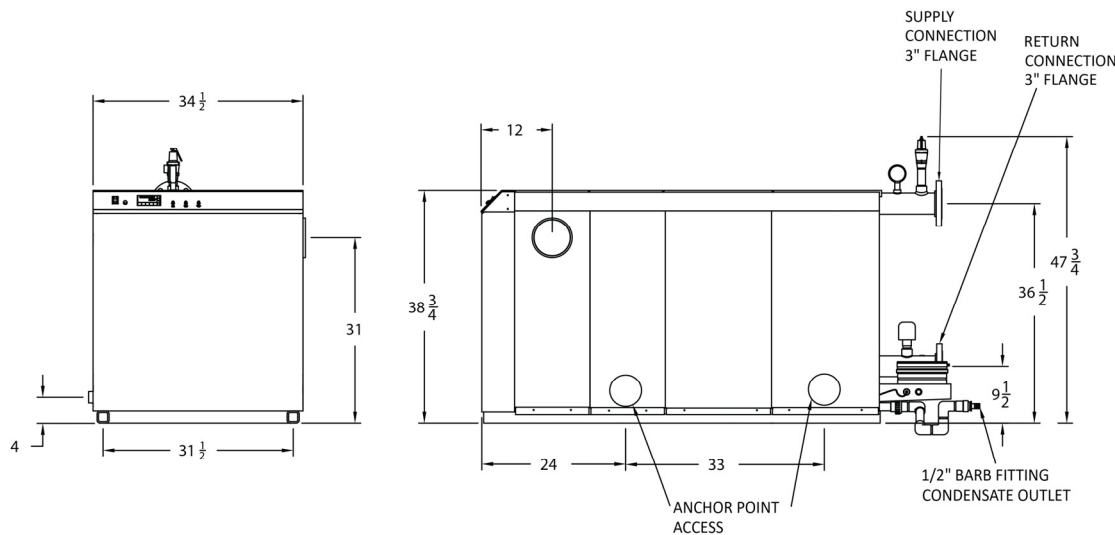

**RIVERSIDE HYDRONICS RESERVES THE RIGHT TO CHANGE THE DESIGN AND SPECIFICATION WITHOUT NOTICE.**